



Kay Industries

PHASEMASTER®

Rotary Phase Converters

INSTALLATION MANUAL

TYPE MA **General Purpose Multi-motor Converter**
TYPE MA-A **Type MA Converter with automatic control**
TYPE MA-R **Type MA Converter with switch and fuses**

CONTENTS

I.	BEFORE YOU START	2
II.	SIZING THE SINGLE-PHASE SERVICE - FUSE RATINGS AND WIRE SIZES	3
III.	INSTALLATION	3
	SELECTING CONVERTER LOCATION.....	3
	GENERAL WIRING INSTRUCTIONS TYPE MA	4
	CONNECTING TYPE MA-R CONVERTER WITH BUILT-IN SWITCH	5
	CONNECTING TYPE MA-A AUTOMATIC CONVERTER.....	5,6
	0302-MA CONNECTION DIAGRAM	7
	0302-AUTO CONNECTION DIAGRAM.....	8
	0302-MA-R CONNECTION DIAGRAM.....	9
IV.	CONVERTER CHECKOUT	10
V.	OPERATION & MAINTENANCE.....	11
	LUBRICATION	11
	INSPECTION.....	11
	MAINTENANCE SCHEDULE	11
VI.	IN CASE OF TROUBLE.....	12

WARRANTY

Kay Industries, Inc. (the manufacturer) guarantees all products of our manufacture against faulty material or workmanship for a period of two years from date of installation or 25 months from date of shipment from factory, whichever period first expires.

Any part that you return to us within this warranty period showing unmistakable defect in material or workmanship will be renewed or replaced at our option F.O.B. factory without charge. The final decision that an original defect existed shall rest with the manufacturer.

The liability of the Company is limited to the renewal or replacement of the defective part. In no case will the Company be liable for damage or loss incurred because of interruption of service or for consequential damages, transportation, labor or expense required to repair or replace defective units.

Kay Industries will not be responsible if its products have been improperly installed in any way. This warranty shall not apply to any of the manufacturer's products that must be replaced because of normal wear, that have been subjected to misapplication, misuse, neglect, accident or that have been repaired or altered outside of the manufacturer's factory unless expressly authorized by the manufacturer.

I. BEFORE YOU START

Kay Industries has designed the **Phasemaster**[®] Rotary Phase Converter for ease of installation by anyone having basic electrical knowledge and mechanical skills. If you are unsure of how to proceed or do not thoroughly understand these instructions, we strongly recommend that you obtain the assistance of a licensed electrician.

These instructions are based upon Article 455 of the National Electric Code. Although we present a practical set of guidelines for converter installation, we do not intend to supersede or modify the requirements of the National Electric Code or any applicable local codes. We suggest that you consult these references to determine whether your particular installation complies with applicable regulations.

Verify that the load does not exceed the “Largest Motor” rating on the converter nameplate. We also suggest that you **temporarily connect the phase converter and the load** to verify performance before proceeding with the permanent installation.

Whether this is your first phase converter installation or your one-hundredth, there are a few do’s and don’ts that you should observe:

DO:	DON’T:
DO: Fuse the converter separately from all other loads. Use only properly sized dual element time delay fuses sized according to the Selection Chart on Drawing 0302-MA.	DON’T: Use circuit breakers instead of a fused switch to protect the converter. They do not withstand the repeated inrush current required to start the phase converter. The breaker will either trip during starting, thus preventing the converter from reaching full speed, or it will cause a shutdown of the converter that could result in damage to the connected load. Increasing the size of the breaker will result in poor protection that could damage the converter and wiring. It is okay to use a circuit breaker in the single-phase panel that feeds the converter and load if that breaker is sized according to the procedures described in this instruction book.
DO: Always be certain that power is off before removing any covers or connecting any wires.	DON’T: Draw any other single-phase load through the converter fuses. Refer to installation drawing 0302-MA.
DO: Remove the converter from the skid	DON’T: Bolt the converter down.
DO: Use the ring terminals connected to the converter wires. Crimp only with an approved crimping tool of the correct size for the terminals.	DON’T: Use wire nuts or twist type connectors to connect the converter.
DO: Connect all single-phase loads, including controls, only to L1 and L2.	DON’T: Connect the manufactured leg T3 to any control circuits or to any single-phase loads.
DO: Insulate all connections with rubber and plastic tape or heat shrinkable tubing.	DON’T: Use plastic tape only. It does not have the required mechanical strength to protect the electrical connection.

Failure to observe these basic precautions accounts for the majority of converter system failures.

**READ THIS SECTION CAREFULLY!
MORE THAN HALF OF ALL “CONVERTER” PROBLEMS RESULT FROM
INADEQUATE SINGLE-PHASE SERVICE SIZE AND/OR UNDERSIZED
BRANCH CIRCUIT BREAKERS**

II. SIZING THE SINGLE-PHASE SERVICE - FUSE RATINGS AND WIRE SIZES

It is extremely important to verify that you have adequate single-phase service for the total planned load. The maximum 3-phase current that you can draw is about 50% of the single-phase service. That means a 200A single-phase service will give you approximately 100A of 3-phase through the converter. You must also select the proper size single-phase branch circuit to supply your converter and load.

The converter consumes very little energy when running under load. The service size and branch circuit rating are determined **only** by the amount of connected three-phase load.

To determine your total three-phase load demand:

- Add the total 3-phase full load currents for every load that will operate simultaneously. As a rule you can estimate that every motor will draw 2.5 amps per horsepower at 230 volts. For example, if you plan to run 20 HP simultaneously, your 3-phase full load current will be 50 amps. If you are operating at 208 or 460 volts you must adjust the current accordingly. Use 2.8 amps/HP for 208 volts and 1.25 amps/HP for 460 volts.

To determine the required single-phase branch circuit to feed the converter and load:

- Multiply the total 3-phase full load current by 1.73. This is the exact single-phase current which will you will draw. It is also the **absolute minimum single-phase service** you will need to operate the load. However, the National Electric Code requires that you multiply the 3-phase current by 2.5 (instead of 1.73) to allow for an adequate overload and safety margin. This is a conservative way to select your wire and branch circuit size and will assure your compliance with code. **If you use a breaker of smaller rating than called for by this calculation, it may trip when the converter starts or may be too small to handle the entire planned load.**

To determine the single and 3-phase wire size required, disconnect switch and fuse ratings:

- Refer to the table and diagram on drawing 0302-MA, 0302-AUTO or 0302-MAR

Check the nameplate and note the type of your converter for the proper connection drawing:

Type **MA** converters (Model number format MA-2) require a separately mounted fused switch to turn the converter on and to provide short circuit protection for the converter. Refer to drawing 0302-MA.

Type **MA-A** converters (Model number format MA-2-A) contain fuses and magnetic controls and **do not** require a separate fused switch. Refer to drawing 0302-AUTO

Type **MA-R** converters (Model number format MA-2-R) include a manually operated built-in and switch and fuses. Refer to drawing 0302-MAR

III. INSTALLATION

BEFORE YOU CONNECT ANY WIRES **Be sure all POWER IS OFF at the main panel.**

SELECTING A CONVERTER LOCATION

Pick a location as close as practical to the incoming single-phase service panel or if preferred, near the 3-phase load. It must be a dry location with adequate ventilation free of dirt, filings, chips, sawdust and other debris that could enter the converter through the ventilation intakes. The converter warranty does not cover failure caused by water or foreign material ingress. Kay Industries also offers weatherproof enclosures for outdoor installation.

GENERAL WIRING INSTRUCTIONS

1. Remove the converter from the skid and set it in place on the mounting pads included in the package. **Do not bolt the converter to the floor or any other mounting surface.** Rigid mounting amplifies noise, increases internal vibrations that can loosen terminals and can distort the frame causing the rotor to lock. Kay Industries recommends making a temporary connection to verify the converter is adequate for the load before finalizing the installation. This can be done quickly and may save a great deal of time and labor if an exchange is necessary.
2. Type MA converters are pre-wired to operate on 230 volts unless ordered otherwise. Do not reconnect the leads in the junction box unless you need to operate the converter on 460 volts input. The 460-volt option is only available if indicated on the nameplate. The reconnection diagram is inside the junction box cover. The input voltage of Type MA-A and MA-R converters cannot be changed without additional modifications. Consult Kay Industries if this change is necessary. All phase converters produce three-wire delta output only. ***For four-wire wye output, consult the factory for an appropriate transformer.***
3. For Type MA Converters, mount the fused disconnect switch as close as practical to the converter. Connect the disconnect switch to the single-phase branch circuit wire at the service with wire size not less than shown on Drawing 0302-MA. If the location of the converter is more than 50 feet from the service panel or if using aluminum wire, then increase the wire size appropriately.
4. Connect the load side of your fused disconnect to the converter leads marked L1 and L2 in the junction box. Lead T3 is the manufactured phase. If you are using a three-pole fused disconnect, connect T3 to the third pole on the load side of the switch. If you are using a two-pole disconnect, run T3 directly to the line side of the load disconnect or other load switching device.
5. Connect the single-phase power supply from the line side of your fused disconnect to the L1 and L2 terminals of the load disconnect switch.
6. Ground the converter by attaching the system ground wire to the ground lug in the converter junction box. If you have not grounded your load, do so before proceeding.

Label all wires "L1", "L2" and "T3" uniformly throughout the entire system. This will avoid confusion in wire tracing should any troubleshooting become necessary later.

CONNECTING THE TYPE MA-R CONVERTER WITH BUILT-IN SWITCH AND FUSES

The Type MA-R converter includes built-in switch and fuses which have been appropriately sized for the load. Installation is very simple. Determine the proper single and three-phase wire size from the table in drawing 0302-MAR.

After setting the converter in place, route the three-phase output power cables and ground conductor in properly sized conduit from the phase converter control enclosure to the load and from the service panel to the converter. Make the necessary penetrations in the converter enclosure and secure the conduits at both ends. If you are using flexible multi-conductor cable instead of wiring in rigid or flexible conduit, be certain to use a suitable strain relief fitting where the cables enter and leave the converter enclosure.

Connect the single-phase supply lines L1, L2, and Ground to the input terminal blocks on the converter connection panel. Connect the output cables to the output terminals labeled T1, T2 and T3.

CONNECTING THE TYPE MA-A AUTOMATIC PHASEMASTER CONVERTER

The Phasemaster Automatic rotary phase converter (Type MA-A) is identical in operation and performance to the non-automatic converter (Type MA) except that it is equipped with built-in time delay fuses to protect the converter and controls which allow the converter

- To be remotely started before starting the load
- To shut down when the load is off
- To prevent the load from starting unless the converter is running.

Before proceeding with the installation we suggest you review drawing 0302-AUTO to become familiar with how the converter is connected and electrically interlocked with the load equipment. The Type MA-A converter is designed to turn on and off as required by the load. This control arrangement is accomplished using an adjustable time-delay relay and magnetic contactor that are built into a side mounted pre-wired enclosure.

Type **MA-A** converter connections are divided into three groups. Group 1 supplies single-phase power to the converter. Group 2 controls the starting and stopping of the phase converter. Group 3 wiring coordinates the starting of the converter with the load.

Group 1: Single-phase power connections to the converter

Determine the proper size single-phase branch circuit for the load. This calculation is described in detail in Section II. Route the single-phase input power cables and ground conductor in properly sized conduit from your branch circuit and/or disconnect to the phase converter control enclosure. Use the existing knock-out provided or make a new penetration in the enclosure appropriate to conduit size and secure the conduit at both ends.

Group 2: Three-phase power connections from the converter to the load

Route the three-phase output power cables and ground conductor in properly sized conduit from the phase converter control enclosure to the load. If required, make a new penetration in the enclosure appropriate to your installation and secure the conduit at both ends.

Group 3: Control power connections between the converter and the load

Wire these circuits with an appropriate length of 4 or 5 conductor cable or individual conductors within a conduit. (Four conductors are actually required, but it doesn't hurt to have a spare when dealing with control wiring.) Wire size AWG 14 is adequate for all control wiring. Route this wire between the load and the phase converter control enclosure.

Group 1 & 2 Wiring:

With conduits and cables in place, you are ready to make the power connections.

1. Connect the Group 1 input power leads to L1 and L2 on the input terminal block in the converter enclosure. Connect the ground (NOT NEUTRAL) wire to the terminal marked "Ground". Make the corresponding connections in your branch circuit panel.
2. Connect the ground cable from your load to the terminal marked "Ground".
3. Connect the Group 2 load cables to the output terminal block to the output terminals designated T1, T2, and T3 in the starter panel enclosure. Tighten the terminal blocks and label the cables at both ends T1, T2, and T3 to correspond with the connections within the converter enclosure. Later, you may change these connections at the load to obtain the correct rotation, but keep the labels on the cables so that they are marked consistently throughout the system.
4. Be sure that T3 is not supplying power to any relays or other control components inside the load.

Group 3 Wiring: Connecting the type MA-A converter with the load controller

Generally, the load is equipped with a stop-start switch or some other type of pilot control or actuator switch. This actuator could be a pressure switch on a compressor, a thermostat on an air conditioner, or a float switch on a pump. Each of these pilot switches is connected to the starter circuit of the load equipment. Since these start-stop arrangements differ widely among equipment types and manufacturers, there is no single method of connecting them all. However the following information will aid you in connecting the control circuits.

The phase converter must be operating before the load can be turned on. To accomplish this, the pilot control (actuator switch) of the load must be connected to the converter. The converter contains a timing relay that will close an output control contact after a short time delay. This will assure that the converter is started and 3-phase power is available at the load terminals.

1. Using two (2) of the Group 3 control wires installed, connect the load's start-stop switch or normally open starting contact across the terminals marked "Actuator Contacts From Load Controller" in the converter enclosure. Note, unless you have specified a low voltage control for the converter, there will be 230 volts present across these contacts. The actuator contacts from your pilot control (PLC, float switch, pressure switch, etc.) which turn the converter on and off must be rated for 230 volts.
2. The remaining two (2) Group 3 control wires will be connected inside the converter control enclosure to the terminals marked "Output to Load Controller." This is a timed contact which will close when the converter is up to speed. Connect the opposite end of these wires in series with the load contactor circuit between the contactor coil and the control voltage source. Consult the load controller wiring diagram if necessary to determine the best point to break into the control circuit. The "dry contact" from the time-delay relay of the converter will now make and break the load contactor voltage as the converter is turned on and off whenever the load is called for by the load actuator switch.

After tightening all terminals and checking wiring, adjust the time-delay relay to approximately 10 seconds, start the converter and observe that the load does not become energized until after the converter has reached full speed. If the converter does not reach full speed within ten seconds, there may be problem of excessive utility line voltage drop or inadequate transformer capacity. Refer to the section of the main manual titled **In Case of Trouble**. If the load starts before the converter reaches full speed, increase the time on the time-delay relay. Once the time delay relay is set up, turn off all power and replace all covers.

Single-Phase Input from Main Utility Supply Panel

208, 230 or 460 Volts

See Note 5 For Branch Circuit Sizing

Phasemaster® Type MA Rotary Phase converter

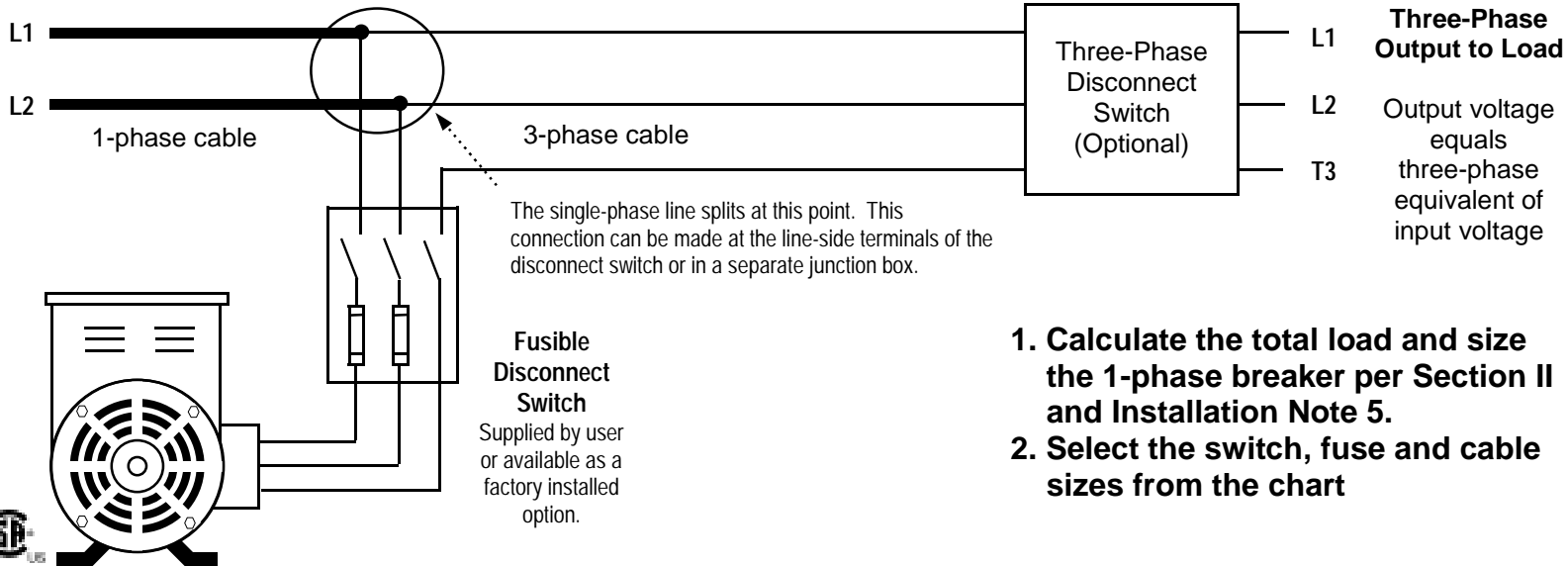

1. Calculate the total load and size the 1-phase breaker per Section II and Installation Note 5.
2. Select the switch, fuse and cable sizes from the chart

DISCONNECT SWITCH AND WIRE SIZE SELECTION CHART									
Model No.	Start HP	230 Volts				460 Volts			
		Switch	Fuse	1-Ph Cable	3-Ph Cable	Switch	Fuse	1-Ph Cable	3-Ph Cable
SD-60	1.5	30	10	#12	#12	30	5	#12	#12
MA-00	2	30	15	10	12	30	7.5	12	12
MA-0	3	30	20	8	10	30	10	10	12
MA-1	5	30	30	8	10	30	15	10	12
MA-1B	7.5	60	35	6	8	30	15	8	12
MA-2	10	60	40	4	8	30	20	8	10
MA-3	15	60	60	1	6	30	30	6	10
MA-4	20	100	80	1/0	4	60	40	4	8
MA-5	25	100	100	3/0	4	60	50	2	6
MA-6	30	200	125	4/0	2	60	60	1/0	6
MA-7	40	200	150	2-1/0	1/0	100	75	2/0	4
MA-8	50	200	175	2-2/0	2/0	100	80	2/0	4
MA-9	60	200	200	2-2/0	3/0	100	100	3/0	2
MA-10	75	N/A	N/A	N/A	N/A	200	150	N/A	1/0

INSTALLATION NOTES
1. This diagram does not replace or supersede any requirements of local, state or national electric codes.
2. Use only dual element time delay fuses to protect the phase converter.
3. Do not bolt converter to floor. Use vibration pads supplied with unit.
4. Do not connect control circuits to manufactured phase, T3.
5. National Electric Code (NEC) requires single-phase cable and branch circuit to be rated for 250% of three-phase load current.
6. The 3-pole converter switch is used to provide electrical isolation when the converter is off. But it is only necessary to fuse converter input lines L1 & L2. T3 is not fused. A 2-pole fusible switch may be substituted if the optional 3-pole load disconnect is used.
7. No-load output voltage L2-T3 will exceed L1-L2 by 12-15%. Voltages will balance when load is connected.

Wiring Notes:

- Conductor sizes are based on type THHN, 90° C, copper conductors in 30° C max. ambient.
- These are minimum recommended sizes for the load motor HP rating indicated.
- For larger loads refer to installation note 5 and increase conductor size accordingly.
- Increase wire size for Aluminum conductors or runs in excess of 50 feet.
- Consult National Electric Code for runs in excess of 50 feet or for aluminum conductors.
- Do not use circuit breakers. See Installation Note 2.

Connection Diagram for Phasemaster Rotary Phase Converter with Field Mounted Manual Controls

0302-MA

Single-Phase Input from Main Utility Supply Panel

L1
L2

Phasemaster® Type MA-A or DP-A Rotary Phase Converter with built-in fuses and automatic magnetic controls for remote actuation.

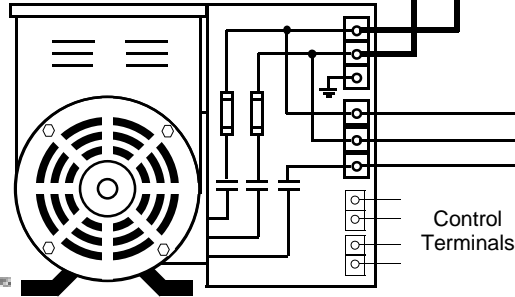

Three-Phase Output to load

T1
T2
T3

Sequence of Operation

1. Input actuator contact from load controller closes magnetic starter M and energizes timing relay TD.
2. Converter starts and the adjustable timing relay waits 1-5 seconds until converter reaches full speed.
3. Output contacts 1-3 then close allowing the load to start.

Control Panel Connection Detail

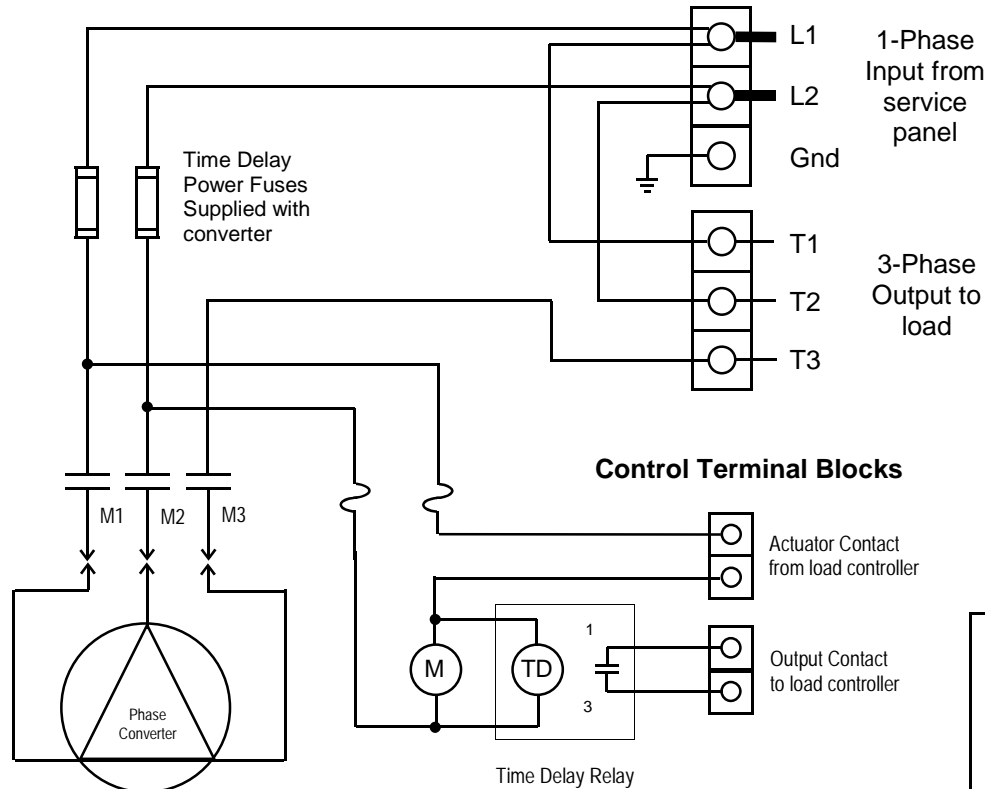

WIRE SIZE SELECTION CHART							
Model No.	Start HP**	230 Volts		460 Volts			
		Fuse*	1-Ph Cable	3-Ph Cable	Fuse*	1-Ph Cable	3-Ph Cable
SD-60-A	1.5	10	#12	#12	5	#12	#12
MA-00-A	2	15	10	12	7.5	12	12
MA/DP-0-A	3/2	20	8	10	10	10	12
MA/DP-1-A	5/3	30	8	10	15	10	12
MA/DP-1B-A	7.5/5	35	6	8	15	8	12
MA/DP-2-A	10/7.5	40	4	8	20	8	10
MA/DP-3-A	15/10	60	1	6	30	6	10
MA/DP-4-A	20/15	80	1/0	4	40	4	8
MA/DP-5-A	25/20	100	3/0	4	50	2	6
MA/DP-6-A	30/25	125	4/0	2	60	1/0	6
MA/DP-7-A	40/30	150	2-1/0	1/0	75	2/0	4
MA/DP-8-A	50/40	175	2-2/0	2/0	80	2/0	4
MA/DP-9-A	60/50	200	2-2/0	3/0	100	3/0	2
MA/DP-10-A	75/60	N/A	N/A	N/A	150	4/0	1/0

* Supplied with converter
** MA-A Start HP/DP-A Start HP

Connection Diagram for Type MA-A and DP-A Phasemaster Rotary Phase Converter with automatic controls

0302-AUTO

**Single-Phase
Input from
Main Utility
Supply Panel**

208, 230 or
460 Volts

See Note 5
For Branch Circuit Sizing

Phasemaster® Type MA-R
Rotary Phase Converter
with built-in disconnect switch
and fuses

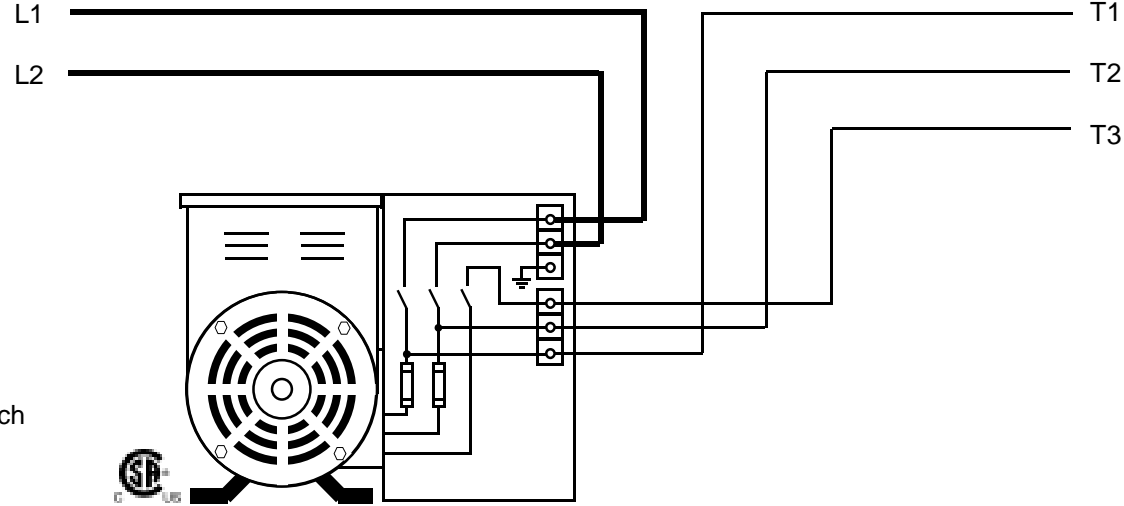

**Three-Phase
Output to
Load**

Output voltage
equals
3-phase
equivalent of
input voltage

See Note 4

WIRE SIZE SELECTION CHART

Model No.	Start HP	230 Volts				460 Volts			
		Switch*	Fuse*	1-Ph Cable	3-Ph Cable	Switch*	Fuse*	1-Ph Cable	3-Ph Cable
SD-60-R	1.5	30	10	#12	#12	30	5	#12	#12
MA-00-R	2	30	15	10	12	30	7.5	12	12
MA-0-R	3	30	20	8	10	30	10	10	12
MA-1-R	5	30	30	8	10	30	15	10	12
MA-1B-R	7.5	60	35	6	8	30	15	8	12
MA-2-R	10	60	40	4	8	30	20	8	10
MA-3-R	15	60	60	1	6	30	30	6	10
MA-4-R	20	100	80	1/0	4	60	40	4	8
MA-5-R	25	100	100	3/0	4	60	50	2	6
MA-6-R	30	200	125	4/0	2	60	60	1/0	6

* Supplied with converter

INSTALLATION NOTES

1. This diagram does not replace or supersede any requirements of local, state or national electric codes.
2. Fuses are supplied with converter. Use only dual element time delay fuses as replacements.
3. Do not bolt converter to floor. Use vibration pads supplied with unit.
4. Do not connect control circuits to manufactured phase, T3.
5. National Electric Code (NEC) requires single-phase cable and branch circuit to be rated for 250% of three-phase load current.
6. No-load output voltage L2-T3 will exceed L1-L2 by 12-15%.

Wiring Notes:

- Conductor sizes based on type THHN, 90° C, copper in 30° C max. ambient.
- These are minimum recommended sizes for the load motor HP rating indicated.
- For larger loads refer to installation note 5 and increase conductor size accordingly.
- Increase wire size for Aluminum conductors or runs in excess of 50 feet.
- Consult National Electric Code for runs in excess of 50 feet or for aluminum conductors.

**Connection Diagram for Phasemaster Rotary
Phase Converter with built-in
Switch and Fuses**

0302-MAR

IV. CONVERTER CHECKOUT

1. Start the converter. Small converters (10 HP and below) should reach full speed in about two seconds. Larger units may require up to seven seconds. Every converter is factory tested prior to shipment and is well within these time limits. If the converter takes longer to reach full speed, your line voltage is dropping which means your service may be inadequate.
2. Check the single-phase utility input supply voltage between L1 and L2 with a voltmeter. It should be 220 to 240 volts on a nominal 230 volt system. In general you should not allow the input voltage to exceed 240 volts on a 230 volt system or 480 volts on a 460 volt system. If the input voltage is too high, the result could be excessive manufactured phase voltage accompanied by load current imbalance.
3. IF YOUR **INCOMING** LINE VOLTAGE EXCEEDS 240 VOLTS, you may need to have the utility company reduce the incoming voltage or install a buck-boost transformer to drop the voltage to an acceptable level. Consult Kay Industries on this subject if you have questions about how to proceed.
4. Refer to the diagram below and measure the voltages between L1-L2, L1-T3, and L2-T3 at points A and B with the converter running but with the load equipment turned off. These are the no load idle voltages. The L2-T3 voltage is the manufactured phase voltage. It will be higher than the other voltages. All voltage measurements should be taken line-to-line. Line-to-ground voltages **are not** significant measurements of converter performance.
5. The normal output voltage measured between L2 and T3 will range from 260 to 290 volts on a 230 volt system and 490 to 525 volts on a 460 volt system depending upon the input voltage between L1 and L2. This is a **normal** idle condition. There is no danger to the load from the L2-T3 voltage. Although it is somewhat high when there is no load, this voltage will drop when the converter begins to supply power to a load and will balance within 2-5% of the other phase voltages as the converter approaches full load.

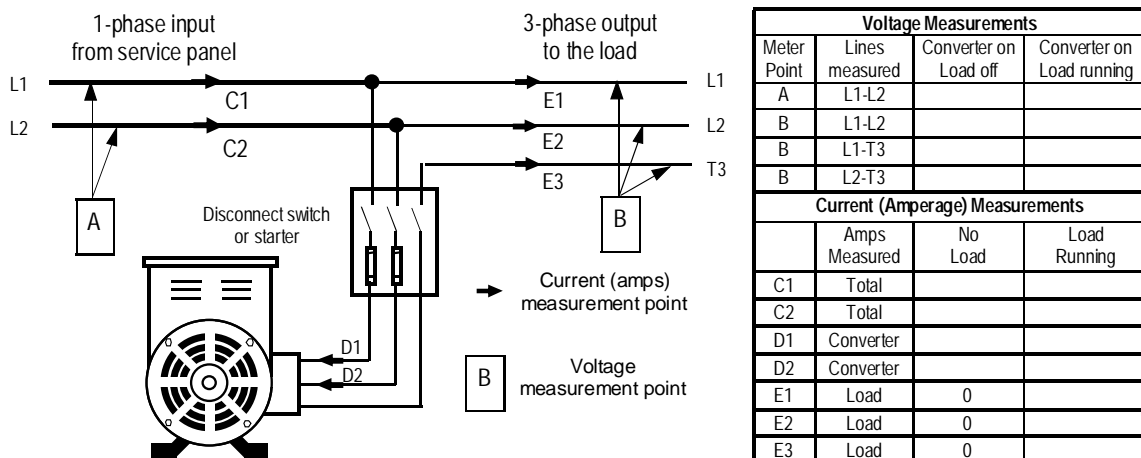

6. Make a record of all voltages at each measurement point and retain these readings in a log for future reference. Large deviations could indicate problems with either the utility supply voltage or the load conditions.
7. If load motors rotate the backwards, reverse the L-1, L-2 connections at the load.

V. OPERATION & MAINTENANCE

The **Phasemaster**[®] converter may operate continuously with or without a load. However, the converter operating temperature and noise level will be higher at no-load than under loaded conditions. The converter will not be damaged nor will it overheat if operated unloaded.

1. **Never start the Phasemaster[®] converter under load.**
2. Wait until the converter reaches full speed before turning on any load.
3. Whenever possible, avoid applying more than one load at the same time.

MAINTENANCE

The converter requires very little maintenance other than periodic lubrication, cleaning and inspection.

LUBRICATION

Phasemaster[®] converter bearings are pre-packed with a heat, moisture, and rust resisting polyurea based lubricant rated to operate in the temperature range of -35 to +350° F. This initial charge plus a generous additional amount placed in the bearing housing during manufacturing is normally enough to last the lifetime of the bearing. Converters exposed to severe operating conditions of high heat, moisture, dirt or limited ventilation require periodic lubrication. To grease the bearings in a smaller converter not having grease fittings, remove the end-bells and remove the excess grease. Replace it with a generous supply of a compatible lubricant such as Chevron SRI. To lubricate a larger converter, inject a small amount of grease slowly into the grease fittings. Do not use high-pressure equipment. Take care not to saturate the windings with grease over an extended time. Remember, this grease goes somewhere when it leaves the bearing. **Lithium based lubricants are incompatible and may cause bearing failure.**

INSPECTION

Inspect the converter periodically to verify the ventilation slots are clear. In dusty or dirty environments, remove the end-bells and clean the windings of excess grease, dust and debris. On Type MA-A or MA-R converters, inspect all power and control components for loose connections and damaged or pitted contacts. Clean, tighten or replace as necessary.

MAINTENANCE SCHEDULE

Action	Monthly	Semi-Annual	Annual	Bi-Annual
Grease Bearings with Chevron SRI or an equivalent lubricant.			X	
Check voltage L2-T3 and record in log.	X			
Listen for abnormal noise or excessive vibration. Tighten rods and bolts if needed.	X			
Shut down converter and blow out dust and debris from stator.		X		
Open control compartment and inspect power and control connections and contacts. Clean and tighten terminals.			X	
Remove end bells and rotor. Clean Stator. Check bearings for wear. Reassemble using 40 Ft-Lb. torque on all bolts and nuts.				X

This is a suggested maintenance schedule. Your particular application may require more or less frequent attention. We suggest that you begin with this schedule and modify it as needed over time. The **Phasemaster**[®] rotary converter is a highly reliable machine. With this equipment, as with all electromechanical devices, problems do occur. If you experience difficulty, our factory engineers will be happy to assist you by telephone.

VI. IN CASE OF TROUBLE

Condition	What to look for	Corrective action
Converter does not start. No sound.	Check power source with a voltmeter. L-1 to L-2 should read 230 volts (or 460 volts in a 460 volt system).	Restore power. Reset main breaker and replace with correct size if too small.
	Check the fuses by removing them and testing with a continuity checker or ohmmeter.	Replace fuses if needed.
	Check for loose terminals. Be sure lugs are not crimped on cable insulation.	Tighten or re-terminate as required.
Converter hums but does not start.	Be sure that no load device is starting with the Phasemaster. The converter should be running before any load is placed on it	Turn off all loads and re-start the Phasemaster.
	Be sure that the incoming single-phase lines (L-1 and L-2) are properly connected to L-1 and L-2 in the converter junction box. Do not connect either incoming line to T-3 of the converter.	Connect the power source to L-1 and L-2 in the converter. Connect T-3 to the load only.
	Make sure the rotor moves freely by moving it with a screwdriver or other tool with power off.	Loosen bolts and re-tighten to free rotor. If rotor does not turn freely after doing this, call factory.
Converter starts and breakers trip	Check to be certain of the time-delay characteristics of the breakers. They should have similar characteristics to time delay fuses. Ordinary household type breakers are not suitable.	Replace with delay type breakers or time delay fuses. Do not oversize the breakers.
Load(s) always trip overloads during or shortly after startup	Check the line voltage (L-1 to L-2) with an analog voltmeter during start and determine the amount of line voltage drop. Check transformer capacity. If the line voltage drops more than 10% of no load line voltage, take corrective action.	Increase supply line cable size and transformer size if required. Your power company can usually help with transformer problems.
A loud humming noise or chatter comes from the load starting relay.	Check voltage between L-2 and T-3. If voltage remains below 200 volts (for a 230 volt system) or 185 volts (for a 208 volt system) after the motor starts, the converter is too small for the application.	Contact factory for further assistance or possible exchange.
	The manufactured phase T-3 could be connected to the motor starting relay. Check to ensure correct voltage on this relay coil.	Rewire the control coil circuit so that T-3 does not energize the starter coil.
The voltage measured between L-2 and T-3 is about 30-40 volts higher than the line voltage (L-1 to L-2) with no load applied to the Phasemaster.	This is a normal condition and verifies correct operation of the Phasemaster. When the load is applied, this voltage will be reduced as the load increases. No damage will occur to properly connected equipment.	This condition requires no action.
Load does not start or run properly.	Check the converter output voltages under load conditions. L1 to L2 should remain within a few volts of 230 or 460. L2 to T3 may drop momentarily below 180 (or 400) but recover to 220 (440) or above.	If the L2 to T3 voltage remains below 210 (420) volts, the converter may be too small for the application. Contact factory for recommendations or possible exchange.
Excessive noise or vibration.	Noise and vibration are usually the result of a resonance caused by a mounting surface that does not support the converter well. These problems also occur when the converter is bolted tightly to any surface.	Be sure to remove the converter from the shipping skid and place it on a substantial floor using the shock absorbing pads supplied with the converter. Do not bolt the converter to any surface.
The three-phase currents are not equal.	If the load comes up to its rated load and none of its three legs exceeds its nameplate F.L.A. rating, there is no problem. If the L1 and L2 legs are significantly higher than the T3 leg (measured at the load input, not the converter input) then a larger converter or correction capacitors may be required.	Consult with factory to review application.



Corporate Office
604 N. Hill St.
South Bend, IN 46617
800-348-5257 • 574-289-5932(fax)
www.kayind.com

Western Region Office
4127 Bay St. Suite 6
Fremont, CA 94538
510-656-8766 • 510-657-7283 (fax)
info@kayind.com