

HOW PHASE CONVERTERS HELP APPLY MOTORS: PART 1

Many prospective users of 3-phase machines face a lack of 3-phase utility service. A phase converter can solve the problem by letting a 3-phase load operate from a single-phase supply. This first of two parts defines converter types.

LARRY H. KATZ Chief Engineer,
Kay Industries Inc., South Bend, Ind.

T rue enough, electric utility companies distribute 3-phase power to large industrial and commercial customers, as well as areas of high load density like central business districts. Yet, utilities have never found it economical to run 3-phase service to residential areas or to certain small businesses. Thus, many facilities have no 3-phase service. Commonly affected are small businesses that depend on equipment with 3-phase motors, such as bakeries, woodworking shops, laundries, printers, service stations, car washes, bowling alleys, and small machine shops.

Phase converters were first developed in the 1950s to circumvent the problem on agricultural equipment. In recent years, industrial and commercial application has expanded dramatically. The trend is driven by economic factors including utility charges for extending 3-phase lines, construction delays in obtaining new service, and limited availability of single-phase equipment.

Utilities now come under great



Typical rotary phase converter, with ratings to 100 hp, suitable for equipment such as compressors, pumps, machine tools, and woodworking machines.

pressure from regulatory agencies to justify capital investments before granting rate increases. They respond by scrutinizing requests for service extensions. If the investment in extending a customer line can't be paid back

fast enough through energy revenues, the utility will charge the customer for the new service.

Charges vary according to terrain, but it is widely accepted that line extension costs range from \$30,000 to \$90,000 per mile,

depending on the complexity of the change. A common average is \$50,000. The charge to extend a line even a short distance can be prohibitive for a small business. Then there is the additional expense of installing phase distribution panels in the building. Even when the utility agrees to bring in new service, the time lapse before a line is installed can cost the business substantial revenue.

Three-phase motors are well-established in industrial machinery. They are generally more efficient, less expensive, more readily available, and more reliable than equivalent single-phase motors. Therefore, many manufacturers design 3-phase motors into their equipment, often without considering 3-phase service availability. Many owners of such machines, lacking 3-phase service, try to substitute a single-phase for a 3-phase motor. Unfortunately, they usually find the availability of integral-hp single-phase motors to be limited, especially above 10 hp. Special motor designs such as multispeed types or custom flange arrangements, can make finding a single-phase replacement impractical if not impossible. In this context, a converter can adapt any 3-phase machine to single-phase power service.

The potential savings a phase converter can bring can be breathtaking compared with the alternative utility costs. Documented savings of \$20,000 and more are commonplace. Still, the use of phase converters remains a mystery to many who could benefit most. Chief reasons are widespread anecdotal accounts of field problems and other misunderstandings of application. Nonetheless, the connected capacity of motors operating on phase converters of all types in the U.S. exceeds 3 million hp. Some service records exceed 35 years.

Coming of age

The two types of phase converters are *static* and *rotary*. The principles of both are documented in ac theory dating to the turn of the century. But the modern static phase converter did not become commercially popular

until the mid 1950s. The converter truly came of age in the 1960s as rotary types appeared. Predictably, increased converter use spawned a greater incidence of misapplication—most of it avoidable. Successful application of a phase converter depends not only on an understanding of its capabilities and limits, but also on starting characteristics and operating demands of the load. Nearly all application problems come from ignoring this reality.

Understanding how converters work starts with knowing how they are connected. Every converter requires the two single-phase utility lines, L1 and L2 in Figure 1, to connect to both converter and load. In other words, converter and load are in parallel on the single-phase line. The third wire or *manufactured phase* (T3 on all figures in this article) is the only lead directly from the converter. The converter's job is to produce enough voltage on the manufactured phase to create sufficient motor starting and running torque. It must also produce a set of reasonably balanced currents to each load phase. Reaching these performance goals depends on many variables, including converter type, load magnitude, power factor, and single-phase supply stability.

Static converters

Construction, operation.

A static converter (in industry parlance, a "static") has no moving parts. It occupies the lower end of the converter capability spectrum, but it usually has a price advantage over a "rotary." All statics use capacitors to create the

manufactured phase voltage. This voltage is shifted 90 electrical degrees relative to incoming line voltage. When this "out-of-phase" voltage is applied to one coil group of an induction motor, its resulting magnetic field interacts with the field produced by the utility supply in an adjacent coil. The outcome: motor starting and running torque.

A motor usually draws five to eight times full-load current during start. Thus, to get the motor up to speed, it takes about five to eight times as much converter capacitance as it takes to keep it running. A static converter does it with two sets of capacitors: one for starting; another for running. Starting capacitors are electrolytic because of their compactness. Run capacitors are oil-filled.

By far the most common and least costly version of static converters is the *capacitor phase-shift* or simply *capacitor* type. It is characterized by low cost, small size, and limited load capability. As mentioned, the capacitor-type converter uses a combination of start and run capacitors to accelerate the load and maintain running current balance, Figure 2.

Starting capacitors are switched

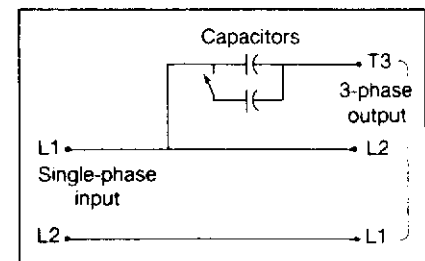

Figure 2 — Simplified equivalent circuit for a capacitor phase-shift static converter.

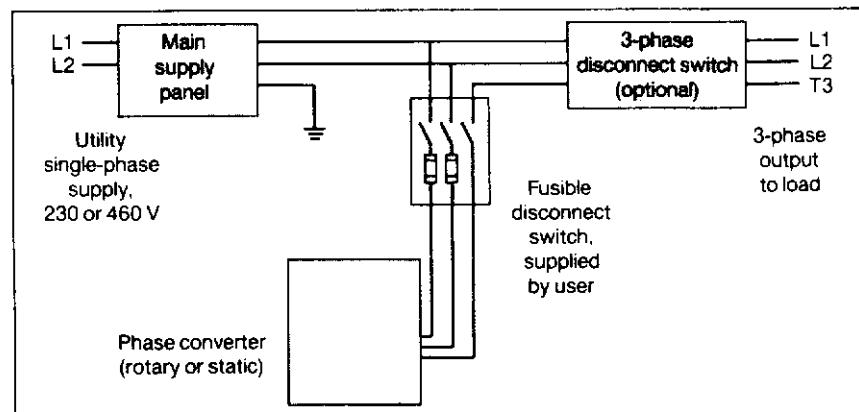

Figure 1 — Typical phase converter system.

in and out of the circuit by a timer or relay, which senses voltage on the manufactured phase during start. As the motor accelerates to full speed, inrush current falls off and manufactured phase voltage rises. The relay responds to this back voltage from the motor by opening a set of contacts, switching off the starting capacitors. Similarly, if the load causes the motor to slow, the resulting fall-off in manufactured phase voltage makes the contacts close again and bring the starting capacitors back into the circuit to re-accelerate the motor. Thus, the converter tries to hold constant load output.

A popular, inexpensive home workshop version of the capacitor phase shift converter is the *start-only* variety. It has a set of starting capacitors, but none for running. They are in the circuit long enough to get the motor to speed; then they switch out. In effect, the start-only converter is little more than an electric "rope starter" for a 3-phase motor. After start, all capacitors are switched off and the motor is simply allowed to single-phase. This condition is tolerable if the motor is loaded to no more than two thirds of nameplate power. However, single-phasing is a common cause of motor failure, so this converter is not a serious candidate for most commercial or industrial applications.

The capacitor-type converter has no way of adjusting output voltage. Thus, it will always have some phase current imbalance. The only way to compensate for it without frying the motor is to derate the motor. Normally, a capacitor converter can produce only 70 to 85% of motor nameplate power rating. Any higher load would cause one phase to carry an extremely disproportionate current compared with its winding capacity. Thus, a 5-hp motor hooked to a 5-hp capacitor-type converter would produce 4 hp or less. To try for full nameplate output from the motor would almost certainly cause burnout. A notable exception: low-power-factor loads. Low-speed motors (1,200 rpm or less) have characteristically low power factor. In many situations, a

capacitor-type converter can operate this type of motor up to full nameplate power. Exceptions aside, inability to provide balanced current at full output is why capacitor-type converters serve mostly on light-duty loads such as machine tools—especially true of the start-only type.

The most versatile static is the *autotransformer* type, Figure 3. It consists of an autotransformer besides start and run capacitors. It steps up incoming line voltage and applies it to the load through the capacitor. The autotransformer static uses the same start-run

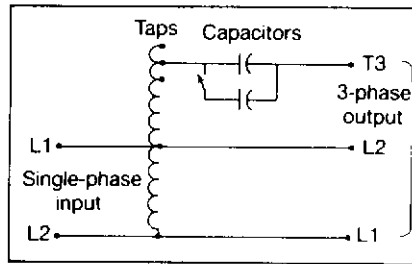

Figure 3—Simplified equivalent circuit for an autotransformer static converter.

switching mechanism as the capacitor type. But the added advantage of taps on the autotransformer allows adjustment of the manufactured phase voltage to produce optimal current and voltage balance. This feature lets the autotransformer static supply full nameplate output on most motor loads. These converters have been applied successfully on many types of equipment, such as fans, pumps, and elevators. They have excellent starting torque and, like all static converters, are nearly loss-free.

The common design characteristic of all static converters is the use of a high-capacitance start and low-capacitance run circuit. Because these capacitors are sized specifically for the start and run conditions of the load being operated, they are *dedicated* to that motor. Thus, a static converter can operate only one motor at a time. Also for this reason, static converters cannot be ganged or paralleled—their capacitances would be additive and their start-cycle switching sequences could not be directed to

a specific load motor.

Ratings, dimensions, prices. Static converters are widely available in ratings from under 1 to more than 50 hp. They are compact and usually suitable for wall mounting. Some capacitor statics are small enough to mount on the driven equipment. Autotransformer types are larger and heavier.

A 5-hp capacitor static weighs less than 25 lb and sells for \$150 to \$350. The lower pricing applies to the start-only version. An autotransformer converter of the same rating weighs about 150 lb and costs around \$800. The autotransformer brings the higher weight and price—clearly a substantial premium.

At 25 hp, differences are more pronounced. The capacitor type weighs under 90 lb and costs \$650 to \$1,300. The autotransformer type weighs over 400 lb and sells for \$2,750. Weight and price relationships for other ratings are roughly linear to these.

Rotary converters

Construction, operation. A rotary phase converter is an induction machine that operates on a single-phase supply and produces a true 3-phase output. It can supply the full rated input requirement of any 3-phase motor (including service factor), resistance, or rectifier load. The manufactured phase of the rotary converter is a true measurable sinusoid, unlike that of the static type.

A common misconception is that a rotary converter is similar to a mechanically coupled motor-generator set. In fact, the converter is a single-armature device similar to a 3-phase induction motor. It has a stator frame with a symmetrical 3-phase winding and a specially modified squirrel-cage rotor. A large capacitor bank is placed across a coil group between one input line and the manufactured phase, Figure 4.

When the converter is energized, single-phase voltage is applied to one winding group. This produces an internal magnetic field proportional to that of the applied single-phase line. The capacitor bank provides a phase-shifted

voltage to an adjacent coil group. This creates another internal field which produces rotor torque.

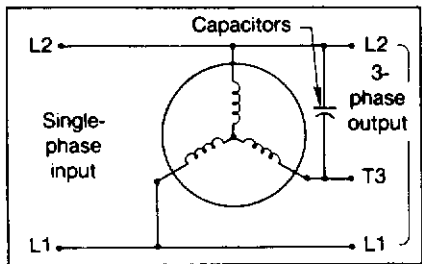

Figure 4 — Simplified equivalent circuit for a rotary converter.

In a sense, the rotary converter contains its own simple static converter for starting. As the rotor spins, it picks up a replica of the utility supply through induction. The rotor current, in turn, creates its own field and, as the rotor passes each stator coil group (each separated by 120 mechanical degrees), the single-phase rotor field is replicated in the other two coil groups. The result is true 3-phase sinusoidal output with each phase shifted by 120 deg. Magnitudes of the three phases differ because of the capacitors and induction inefficiencies but, unquestionably, the output voltage produces a rotating 3-phase field in a 3-phase motor.

The process is analogous to a transformer in which the rotor acts as a secondary winding on bearings. In fact, a rotary converter is sometimes called a rotating transformer. This transformer has a 1:1 turns ratio. That means, whatever the single-phase input, the converter puts out a 3-phase version of the same voltage.

The output of a rotary converter is 3-wire closed delta. It cannot be changed to 4-wire wye output. If such output is required, a delta-wye transformer must be used. In practice, it is often possible to work around this problem without a transformer. Loads rated for 208/120 V usually require the 120-V leg for control purposes only. In such cases, the 3-wire converter output can connect directly to the 3-phase load with the control circuits wired separately. Except for the largest sizes, converters are usually dual-voltage rated at 230/460 V.

Output characteristics. As with the static converter, two of the three lines in a rotary system come directly from the utility supply, Figure 1. Therefore, the most important output characteristic is behavior of the manufactured phase voltage relative to the utility lines. As Figure 5 shows, output is load-dependent. At no load, the manufactured phase voltages (L2-T3 and L1-T3) are substantially higher than the incoming line voltage. As load increases, the voltage drops so that, at full load, the three voltages are closely balanced. When connected load exceeds converter capacity, the manufactured phase voltage drops off sharply. At that point, the third phase can no longer sustain the voltage needed to maintain rated running torque.

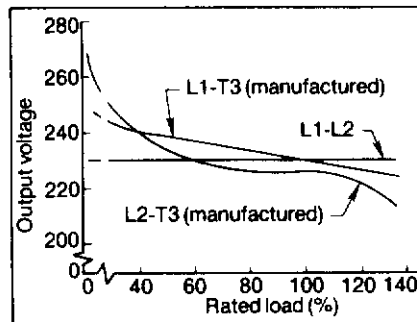

Figure 5 — Output voltage vs. load for a rotary converter with 230-V supply.

An interesting phenomenon occurs when a rotary converter starts a motor. After the motor reaches full speed, it has a supporting effect on the system. As a result, a rotary converter can operate much more total horsepower than it can start at one time. In fact, a rotary converter can power two to four times its nameplate rating as long as only one load motor equals the converter's maximum rating. Thus, a 25-hp rotary converter could easily handle a total of 75 hp if it served a 25-hp motor, the other 50 hp was made up of motors smaller than 25 hp, and they are not all started at once.

Ratings, dimensions, prices. Rotary converters come in ratings from 1 to 100 hp. The practical limit on the single largest motor that can operate from one rotary

converter is about 125 hp. But there is no theoretical limit to total load size converters can serve. Rotary converters may be paralleled indefinitely for any load. This capability is convenient for users who must add system load often, or for applications where utility supply lines could not withstand the inrush currents of a single large rotary converter. The only true converter capacity restriction is the maximum connected single-phase load the utility allows.

A rotary converter is dense and compact. A typical 10-hp unit is about 18 by 18 by 20 in. and weighs 250 lb. Such a unit sells for about \$1,400. At 25 hp, size increases to 22 by 22 by 28 in. and the price goes to \$2,700. Remember, a rotary converter is rated for the largest motor it can start, but it can operate from two to four times that amount in motors of smaller rating. Consequently, the cost per total horsepower capacity is lower for a rotary converter than a static.

Controls. The most common and least expensive control scheme for a rotary converter is a fusible disconnect switch for isolation and short-circuit protection. The converter is manually switched on and runs continuously until it is manually switched off. However, some conditions call for more control or for remote operation. In these cases, a converter may have automatic controls. A magnetic contactor can start and stop the converter from a remote actuator. A timing relay locks out the load until the converter reaches full speed and is producing 3-phase power (about 3 s). Automatic controls serve unattended or intermittently used installations such as lift station pumps, elevators, and air conditioners. **PTD**

For more about phase converters by Kay Industries Inc., circle 501 on the reader service card.

In an upcoming issue, the second part of this article will compare performance characteristics of static and rotary phase converters, and show how to select a converter.